

FQG120T 120 Series I Large Vat Gas Fryer

FQG120T 120 Series I Large Vat Gas Fryer

Models - specifically designed for Popeyes

 2FQG120T

 3FQG120T

Specifically designed for low flue temperature and high-volume frying of bone-in chicken and other fresh breaded products.



Popeyes 3FQG120T

- FilterQuick® fully-automatic filtration
- FQ4000 easyTouch® controller
- Optional Oil Quality Sensor (OQS)

Standard Features

- Thermo-Tube frypot design
- Low flue temperature (<650°F/343°C)
- 120-lb (54-liter) oil capacity
- 105,000 Btu/hr (26,448 kcal/hr) (30.8 kw/hr)
- Frying area: 20" x 20" x 5-3/4" (50.8 x 50.8 x 15 cm)
- FQ4000 easyTouch® controller makes cooking and filtering simple and intuitive.
- Electronic ignition
- Wide cold zone
- Fully Automatic Filtration (AF) with rear oil flush
- 8 GPM filter pump
- Heat tape wrapped filter lines
- Drain safety switch
- Drain flush, 1-1/2" drain valve, 3" drain
- Basket rack(s)
- Stainless steel frypot, door, front, and sides
- Basket hanger(s) with flue deflector
- Casters
- 11" Plate shelf with marine edge
- Solid shortening kit
- Front discharge with 10' wash down hose
- Filter starter kit with envelopes

Options & Accessories

- Optional Oil Quality Sensor (OQS) monitors the health of the oil and indicates with great precision the true point that oil needs to be discarded.
- Dual basket
- Triplet basket
- Full basket
- Splash shield
- Frypot cover
- Swivel Max gas hose

Approved Popeyes Fryer Setups:

3 Vat with OQS & 3 Vat without OQS*

Standard	3 Vat with OQS			3 Vat without OQS		
	Seafood	Fries	Spicy	Spicy	Mild	Mild
Mirror Image	3 Vat without OQS			3 Vat with OQS		
	Mild	Mild	Spicy	Spicy	Fries	Seafood

3 Vat with OQS & 2 Vat without OQS*

Standard	3 Vat with OQS			2 Vat without OQS	
	Seafood	Spicy	Spicy	Mild	Mild
Mirror Image	2 Vat without OQS		3 Vat with OQS		
	Mild	Mild	Spicy	Spicy	Seafood

*With 15' long dispose hose

Ordering Options:

- 1 Standard Store Set
- 1 Mirror Image Store Set
- 3FQ120T without OQS
- 2FQ120T without OQS
- 3FQ120T with OQS

Specifications

The FQG120T low flue temperature fryers are large capacity gas systems, with a 120-lb (54-liter) oil capacity, and a cooking depth of 5-3/4" (15 cm) per frypot. These large vat fryers are specifically designed to fry bone-in chicken and other fresh breaded products.

The FQ4000 easyTouch® touchscreen controller puts basic recipe and menu creation at your fingertips. Additional recipe features are available via our menu creation tool to add product images and translated product names to recipes. As a bonus, your fryer ships from the factory with Popeyes recipes pre-loaded in the controller, ensuring you get the recipes you need from the beginning. The segmented cooking feature allows programming a cook with up to 12 different set temperatures and times as desired for cooking bone-in chicken. Fry station management features monitor and help control food and oil quality, oil life, and equipment performance.

The optional KitchenConnect® Cloud-based service can enhance the speed and frequency of updating new menus for "Limited Time Offers" that can be adopted immediately for execution in the kitchen. The controller has intuitive functions requiring minimal training to operate.

The easy-to-use, fully-automatic filtration (AF) system encourages more frequent filtering, which preserves oil life and allows crews to focus on cooking great-tasting food. Filtration at your fingertip, the closed cabinet, AF system with rear oil flush puts filtration where it's most convenient to operate. The cold zone holds heavy sediment and debris away from the cooking area so that they

cannot cling to fried products or contaminate the oil. The bottom of the frypot is sloped toward the front for fast, thorough draining. A staggered multi-port oil return cleans the entire frypot bottom without needing to use a washdown hose.

An 8 GPM pump makes filtering fast, safe, and convenient, encouraging frequent filtering, which extends the useful life of oil. The filter pan and pre-screen filter have been designed to accommodate the heavy sediment that is seen with fresh breaded products. In addition, the filter pan switch has been designed and made accessible from the front of the fryer, along with the transformer box, for ease of service.

With 105,000 Btu/hr input, exclusive Thermo-Tube design, and controlled flow diffusers, this high performance fryer provides maximum production, forcing energy into the oil, with less going unused up the vent. Exhaust temperatures are 650°F or less. The benefits of this design are fast heat-up and recovery times, low idle costs, lower ambient temperatures, and low gas consumption per pound of product cooked.

This unit is shipped standard with stainless steel frypot, doors, front, and sides.



FQG120T 120 Series I Large Vat Gas Fryer

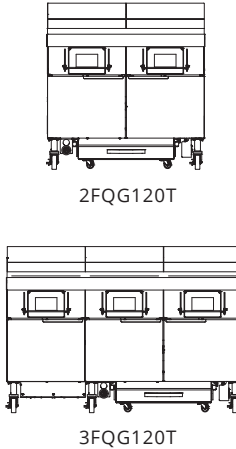
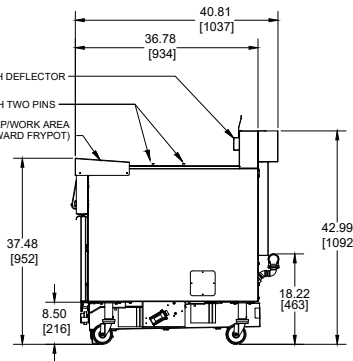
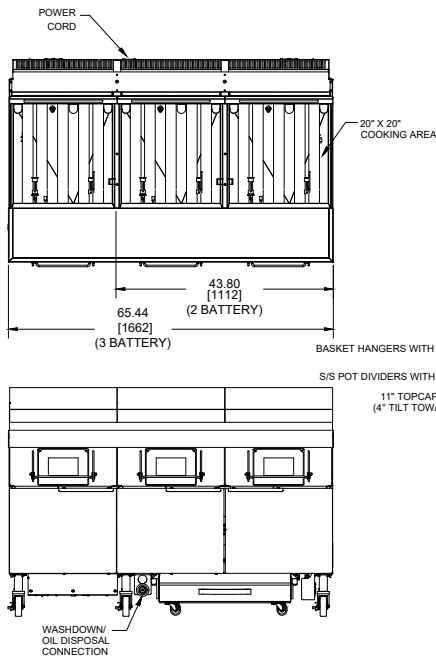

FQG120T Gas Connection Requirements	
Model	Gas Connection Size
2FQG120T	One 1"
3FQG120T	One 1"

Filter locations vary depending on number of fryers in the battery.
 2 battery -- filter located under both fryers
 3 battery -- filter located under fryers #2 and 3

DIMENSIONS										
MODEL NO.	OVERALL SIZE (CM)			DRAIN HEIGHT (CM)	SHIPPING INFORMATION					
	WIDTH	DEPTH	HEIGHT		WEIGHT	CLASS	CU. FT.	DIMENSIONS (CM)		
2FQG120T	43.8" (111.3)	40" (101.6)	43" (109.2)	10" (25.4)	750 lbs. (340 kg)	77.5	72.9	W 53" (134.6)	D 44" (111.8)	H 54" (137.2)
3FQG120T	65.4" (166.1)	40" (101.6)	43" (109.2)	10" (25.4)	1100 lbs. (499 kg)	77.5	82.5	70" (177.8)	44" (111.8)	54" (137.2)

POWER REQUIREMENTS		
MODEL NO.	OPTIONS	
	CONTROLS/ FRYPOT	FILTER
2FQG120T/3FQG120T	120V 5.1A	120V 10A
OPTIONS EXPORT		
2FQG120T/3FQG120T	230V 2.6A	230V 5A

NOTES

1-1/2" (3.8 cm) kitchen main manifold gas supply line required. Gas inlet size (I.D.) should be no smaller than that provided for connection to the fryers. See service manual and/or plumbing codes for proper pipe sizing. Recommended minimum store manifold pressure to be 6" W.C. for natural gas and 11" W.C. for L.P. gas. Check plumbing codes for proper supply line sizing to attain burner manifold pressure of 3.0" W.C. natural or 8.25" W.C. L.P.

POWER CORDS

On 2 and 3 battery units, 1 power cord supplied

IMPORTANT: DO NOT CURB MOUNT

CLEARANCE INFORMATION

A minimum of 36" (91.4 cm) should be provided at the front of the unit for servicing and proper operation, and 6" (15.2 cm) between the sides and rear of the fryer to any combustible material.

HOW TO SPECIFY -- AN EXAMPLE

The following description will assist with ordering the features desired for this equipment:

3FQG120T - Battery of 3 high-volume, low flue temperature gas fryers, 105,000 Btu/hr with automatic filtration, FQ4000 easyTouch® controllers, and casters.

Please specify gas type.

Welbilt reserves the right to make changes to the design or specifications without prior notice.